

WWE
MEMORANDUM

To: Kevin Walters
Region Utility Engineer
Colorado Department of Transportation
Via email: kevin.walters@state.co.us

From: Hayes Lenhart, P.E. and
Peter R. Foster, P.E.
Wright Water Engineers, Inc.

Date: March 6, 2019

Re: Basis of Design Recommendations for the CDOT US 550 / 160 South Connection Project – CDOT Project Number (22420) NH 5501-029

Wright Water Engineers, Inc. (WWE), on behalf of the Florida Consolidated Ditch Company (FCDC), is pleased to provide the Colorado Department of Transportation (CDOT) with this technical memorandum documenting basis of design recommendations for future impacts to the Mason Lateral resulting from the CDOT US 550 / 160 South Connection Project (South Connection Project). The intent of this memorandum is to provide CDOT with a summary of design requirements which should be utilized by CDOT's design-build Contractor when impacts to the FCDC Mason Lateral are expected during the design and construction phases of the South Connection Project.

1.0 DITCH HYDRAULIC CAPACITY

During the irrigation season, the Mason Lateral (Ditch) conveys approximately 14 cfs of irrigation water which is divided into private lateral turnouts located intermittently along the existing Ditch. The Ditch has been known to carry approximately 16 cfs of water during peak irrigation season. The irrigation season typically begins on April 1st and continues through November 1st each year. Periodic stock water is delivered during the non-irrigation season. The rate at which stock water is delivered, is less than or equal to 14 cfs.

Impacts from the South Connection Project which alter the Ditch's location, slope, or cross-section shall utilize 14 cfs and 16 cfs to evaluate changes to Ditch hydraulics, including velocity, flow depth, and freeboard through the Ditch. Minimum freeboard shall be provided as follows:

- 1 foot of freeboard under a flow condition of 14 cfs,
- 0.5 feet of freeboard under a flow condition of 16 cfs.

1.1 Stormwater

The Ditch is currently located to minimize stormwater runoff from entering into the Ditch. No stormwater drainage from The South Connection Project will be allowed to discharge into the Ditch.

1.2 Hydraulic and Hydrologic Design Calculations

Hydraulic design calculations for segments of the Ditch which require a change in location, slope and or cross-section, as a result of the South Connection Project shall be provided. Hydraulic design calculations could include but may not be limited to:

- Results from the Federal Highway Administration (FHWA) HY-8 Culvert Hydraulic Analysis Program or other design calculations at culvert locations.
- Hydraulic grade line profiles and associated calculations for the Ditch under baseflow and stormwater flow condition.
- Hydraulic grade line profiles and associated calculations for stormwater conveyance infrastructure under for various return frequency storm events.
- Model input and output files associated with hydraulic calculations as applicable. These could include United States Army Corps of Engineers (USACE) HEC-RAS model files.

Hydrologic design calculations and grading plans which demonstrate additional surface runoff is not being directed into the ditch shall be provided. Hydrologic design calculations could include but not be limited to:

- Figures and associated calculations for sub-basins in the South Connection Project which estimate stormwater runoff from each sub-basin under various return frequency storm events.
- From time to time the Ditch has been known to clog and overflow its banks for various reasons. Clogs typically happen at culvert inlets, or at a transition from open ditch to a piped section. Considerations for historical ditch overflow discharge and its downstream drainage flow path at these locations shall be provided.

2.0 ACCEPTABLE MATERIALS

The following table provides a description of acceptable materials that should be used to address impacts to the Ditch resulting from the South Connection Project. Please see Attachment A - *Terms and Conditions of the Florida Canal, Florida Canal Enlargement, Florida Farmers Ditch, and Florida Co-Op Ditch (Florida Consolidated Ditch Companies) Ditch Crossing Specifications and Permit* (FCDC Crossing Specifications) for additional requirements.

Location Description	Acceptable Materials	General Notes
Piped Ditch Reaches Under Roadways	Pre-cast concrete (RCP)	Minimum Diameter = 36" or greater Manning's "n" = 0.013
Piped Ditch Reaches Not Under Roadways	Buried Pipe Condition: ADS – Dual Wall HDPE Pipe or acceptable equal.	Minimum Diameter = 36" or greater HDPE Manning's "n" = 0.012
	Not Buried Pipe Condition: Pre-cast concrete (RCP)	Minimum Diameter = 36" or greater Manning's "n" = 0.013
Riprap at Inlet and Outlet of Piped Ditch Reaches	Specific Gravity ≥ 2.5 (AASHTO T85) Angular	Minimum Riprap Thickness = 2 x D ₅₀ Provide Bedding Material for Riprap

Location Description	Acceptable Materials	General Notes
Stormwater Drainage Pipe Under Embankments	Pre-cast concrete (RCP)	Minimum Diameter =18" or greater Manning's "n" = 0.013

3.0 FCDC DOCUMENTATION REVIEW REQUIREMENTS

The FCDC and WWE will review of the following South Connection Project documentation at the following stages of the project:

- Design Drawings and Technical Specifications
 - 30% level **and** CDOT's defined PreRFC level
- Drainage Plans and Report
 - 30% level **and** CDOT's defined PreRFC level

Two onsite meetings to review the South Connection Project and its impacts to the Ditch will be held. **The first meeting** will be **scheduled within 10 calendar days** after receipt of the 30% level project documentation. **The second meeting** will be **scheduled within 10 calendar days** after receipt of the PreRFC level project documentation. At a minimum, the following representatives will be in attendance at each meeting:

- CDOT's design-build Contractor, a WWE representative, CDOT representative, and an FCDC representative.

The FCDC and WWE will review the 30% and PreRFC Level South Connection Project documentation and provide written comments to CDOT and their design-build Contractor **within 21 calendar days** after receipt of the documentation.

4.0 REVIEW OF PRELIMINARY LEVEL DRAINAGE AND CROSS-SECTION PLANS

As part of this Basis of Design Recommendations, WWE reviewed Preliminary Drainage Plans associated with South Connection Project. The drainage plans reviewed are identified as Construction Project Code Number 22420, print date of October 16, 2018. The Cross-Section Plans reviewed are identified as Construction Project Code Number 22420, print date of November 6, 2018.

WWE has only reviewed infrastructure maintained by FCDC, which does not include any privately maintained irrigation pipelines and open laterals that are served by the Ditch which may be affected by the South Connection Project.

The following provides a list of comments associated with WWE's review of the Preliminary Level Drainage and Cross-Section Plans:

1. Ensure that the reconstructed portions of the Ditch do not accept leakage from the proposed highway ditch, or accept runoff from adjacent fields exceeding historical runoff from adjacent fields.

2. No fence posts may be installed within 15 feet of the top of Ditch bank without prior approval from the FCDC. It is our experience that fence posts installed too close to an irrigation ditch may induce leakage. Fences tend to collect wind-blown debris and vegetation and it is difficult to remove this material if the fence is too close to the ditch or lateral. When possible, provide a minimum of 15 feet between the top of the ditch and any fences to allow for maintenance and trash removal.
3. Bermed sections of open unlined Ditch are not allowed by the FCDC. If “above natural grade” sections of the ditch cannot be avoided, they shall be piped. There are two options associated with above ground piped sections:
 - a. **HDPE Pipe in an above ground embankment:** HDPE pipe may be used if the pipe is buried in an above ground earthen embankment. For the embankment, provide an outside slope no steeper than 4 horizontal to 1 vertical with compaction exceeding 95% density per ASTM D698. Provide a minimum of 18 inches of cover over the pipe on all sides. Provide pipe cleanouts every 200 feet. Include heavy gage wire mesh or other alternates to discourage animal burrows in the embankment sections. Install cross-drainage piping through the toe of the embankment as necessary. Erosion control features, such as riprap, shall be provided at the inlet and outlet of the cross-drainage piping.
 - b. **Reinforced Concrete Pipe (RCP) on an above ground embankment:** RCP may be used and installed as an above grade conduit. The conduit shall be supported by an earthen embankment or other above grade structure. For an embankment, provide an outside slope no steeper than 4 horizontal to 1 vertical with compaction exceeding 95% density per ASTM D698. Provide pipe cleanouts every 200 feet. Include heavy gage wire mesh or other alternatives to discourage animal burrows in the embankment sections. Install cross-drainage piping through the embankment as necessary. Erosion control features, such as riprap, shall be provided at the inlet and outlet of the cross-drainage piping. Non-embankment type structures, such as a trestle system, will need to be approved by the FCDC.
4. The use of inverted siphons to convey irrigation water should be avoided. No inverted siphons may be installed to convey irrigation water without prior written approval from the FCDC. If the installation of an inverted siphon is unavoidable, the following shall be provided at a minimum:
 - a. Provide FCDC a written statement explaining why the use of an inverted siphon is unavoidable.
 - b. Provide the ability to drain the siphon.
 - c. Maintain minimum flow velocity's of 3.5 ft/s or more to reduce the potential for sedimentation in the siphon.
 - d. Provide a cleanout for the siphon.
5. Deer fences cannot cross perpendicular through the Ditch. This will lead to maintenance and debris clogging issues. The fence should cross the ditch at a piped section of the Ditch, such as a culvert headwall. A minimum of 5 ft shall be provided between the fence and the headwall.

6. Maintain existing FCDC access points to the Ditch via gates in the deer fence as necessary.
7. Callout and show the existing and proposed Ditch in the roadway cross-sections when applicable to allow evaluation of the elevation difference between the roadside stormwater conveyance infrastructure and the irrigation Ditch.
8. For sections of the Ditch which are to be abandoned, provide Ditch reclamation requirements. Requirements could include but not be limited to fill material and reseeding requirements.
9. Trash racks shall be provided at the entrance to piped sections of the ditch. Trash racks must have a profile slope of 3 horizontal to 1 vertical or flatter. All trash racks shall have a hinged connection to a concrete headwall.

5.0 OTHER CONSIDERATIONS AND REQUIREMENTS

Additional FCDC requirements include:

- No construction activities that may impede water deliveries or operation and maintenance schedules during the irrigation season will be permitted.
- The irrigation season typically begins on April 1st and continues through November 1st each year. Periodic stock water is delivered during the non-irrigation season. The Contractor shall coordinate construction activities which may impede the delivery of stock-water during the non-irrigation season with the local FCDC ditch rider prior to commencing with the activity. Contractor shall obtain written authorization from the FCDC ditch rider prior to commencing with the activity.
- All requirements associated with the attached FCDC Crossing Specifications (Attachment A)
- The Contractor will need to apply for and obtain an FCDC crossing permit prior to the start of construction. Please note this FCDC crossing permit **is separate and independent from** the CDOT and FCDC “Ditch Construction Agreement.” Contractor can apply for this permit by contacting the FCDC secretary:
 - Jessica Mitchell, FCDC Secretary: (970) 749-4675; floridaditch@gmail.com
- Comply with the requirements of Colorado Senate Bill 18-167:
 - Attempt to achieve ASCE 38 utility quality level B or its Successor utility quality level on all utilities within the proposed excavation area unless a reasonable rationale by a licensed professional engineer is given for not doing so; and
 - Document the reasons why any underground facilities depicted in the stamped plans do not meet or exceed ASCE 38 utility quality level A or its successor utility quality level for underground facilities at the point of a potential conflict with the installation of a gravity-fed system.

Kevin Walters, CDOT

March 6, 2019

Page 6

- After CDOT and FCDC have fully executed the FCDC Ditch Construction Agreement, provide notice to the FCDC ditch rider and WWE a minimum of 48 hours prior to commencing construction:
 - Justin Catalano, FCDC ditch rider: (970) 749-9800
 - Hayes Lenhart or Pete Foster, WWE: (970) 259-7411; hlenhart@wrightwater.com; pfoster@wrightwater.com

Attachment(s)/Enclosure(s)

Attachment A - Terms and Conditions of the Florida Canal, Florida Canal Enlargement, Florida Farmers Ditch, and Florida Co-Op Ditch (Florida Consolidated Ditch Companies) Ditch Crossing Specifications and Permit (FCDC Crossing Specifications)

Cc:

Justin Catalano, FCDC

Nancy Agro, FCDC Attorney

Roger Cole, FCDC

P:\061-110\180 CDOT Hwy 550 Mason Lateral Engineering Review\Basis of Design Memo\20190306 - Memorandum - Mason Lateral Basis of Design.docx

Draft
June 10, 2019

Terms and Conditions of the Florida Canal, Florida Canal Enlargement, Florida Farmers Ditch, and Florida Co-Op Ditch (Florida Ditch Companies) Ditch Crossing Specifications and Permit

1. No activities will be allowed during the irrigation season. No activities that may impede water deliveries or operation and maintenance schedules will be permitted.
2. A site visit with Florida Ditch Rider is required prior to any construction to evaluate on-site conditions and specifications of ditch crossing.
3. An engineering design may be required for specific projects if deemed appropriate after the initial site visit. In the case of a bridge crossing and/or culvert installation, an engineering design must be submitted and reviewed by the Florida Ditch Companies' Engineer. Costs to review the engineering design will be at the expense of the Permittee.
4. Changes to private laterals require permission from all private lateral owners or court order.
5. Changes to outlet structures and gates require permission from the Florida Ditch Companies.
6. "CALL BEFORE YOU DIG" - Utility Notification Center of Colorado: 1-800-922-1987
7. Notify the Florida Ditch Rider 48 hours in advance of any future project maintenance.
8. Applicant shall restore Florida Ditch Companies' property to its pre-permit condition upon completion of the project.
9. Permittee shall assume entire responsibility for all activities and uses under this permit and shall save the Florida Ditch Companies free and harmless from any and all expense, cost, or liability in connection with, or resulting from the exercise of this permit including, but not limited to, property damage, personal injury, wrongful death, chemical treatment of water, and, or cleaning operations of ditches.
10. If damage to the ditch company facilities occurs during construction, notify the Florida Ditch Companies prior to repair. The Permittee will be legally and financially responsible for any repairs.
11. Permittee shall maintain and repair installation at all times at his/her sole cost and expense and in a condition satisfactory to Florida Ditch Rider. Should the Permittee neglect to promptly make repairs, the Florida Ditch Companies may make repairs or have repairs made and Permittee shall pay all costs and expenses.

September 2008

Draft
June 10, 2019

Florida Ditch Companies Ditch Crossing Specifications

1. Trench cutting is permitted under small canals (less than 5 feet in width). Boring and jacking installations are required under all main canals (greater than 5 feet in width). Exceptions allowed on a case by case basis with approval from Florida Ditch Companies.
2. For all boring and jacking installations under main canal pipelines, greater than 26 inches in diameter, a geotechnical study will need to be performed to determine the presence of granular material and/or high water table elevation, at the sole expense of the Permittee. The study will include recommendations and a plan for a procedure to prevent failure and a collapse of the bore. Generally, core samples are to be taken near the proposed borehole, at least as deep as the bottom of the proposed horizontal bore. Test results must be submitted and reviewed by Florida Ditch Companies, or its agent, prior to boring activities commencing. Florida Ditch Companies reserves the right, based on test results, to require the Permittee to select an alternate location, or to require additional engineering specifications be implemented, at the sole expense of the Permittee, in order to utilize existing location.
3. Locations that are considered unsuitable or undesirable are to be avoided. These locations may include deep cuts in wet or rocky terrain or where it will be difficult to obtain minimum depth.
4. Location of the boring pits shall be determined at an onsite review. In general, the boring pit should be located a minimum of ten (10) feet from the top edge of berm.
5. The canal cross-section must be reconstructed after the crossing is installed to its original shape. Backfill material must be approved by the Florida Ditch Rider and be compacted to a density equivalent to that of the surrounding in-place earth material or adjacent required earthfill (or 95% of maximum dry density as defined by ASTM D698, standard Proctor Density). Compaction may be accomplished by hand tamping or manually directed power tampers, plate vibrators, walk-behind, miniature or self-propelled rollers, or other means as determined by contractor. Reconstruction in gunited or flowfill sections will require special attention as directed by Florida Ditch Companies.
6. Replace rip-rap to match existing rip-rap along bottom of canal or ditch as directed by Florida Ditch Companies.
7. All utilities crossing shall be installed as specified in Section A; all safety fences shall be installed as specified in Section B; all footbridges shall be installed as specified in Section C; and all culverts shall be installed as specified in Section D.

Section A - Utility Crossings (Drawing FDC 001A and FDC 001B) Water, Sewer, Gas, Electric, and Power

1. All utility crossings including; water, sewer, gas, electric, fiber optic, cable, and power, under ditches and pipelines shall be installed as shown in Drawing FDC 001A and FDC 001B.

September 2008

Draft
June 10, 2019

2. Cross the canal or ditch under a culvert whenever practical. Center the crossing on the culvert pipe.
3. All utility crossings under ditches should have a minimum depth of cover of four (4) feet below the flow line of the ditch or ground surface.
4. All utilities, except gas lines, under canals and ditches shall be encased in a larger pipe or conduit called "casings." Required casing diameter and width are listed in Drawing FDC 001A - Detail A.
5. Casing pipe shall be steel pipe except gas lines which will be installed without casings.
6. If the diameter of the waterline or sewerline carrier pipe is less than 2 inches, a 4-inch minimum diameter casing pipe will be required.
7. Four sets of three creosoted wood blocks strapped to carrier pipe per length are required. Neoprene or PVC runners may be used as an alternative (see Drawing FDC 001A – Detail A).
8. Annular space at ends of casing shall be sealed with grout or use of water tight end seals.
9. Buried utilities shall have a magnetic warning tape installed in trench for detection purposes.
10. Cut-off walls shall be installed on the downgradient end of all utility crossings as shown in Drawing FDC 001B - Detail B. Exceptions allowed on a case by case basis.
11. Permittee must provide and install 5' carsonite, or approved equal, fiberglass surface marker with language identifying utility at right of way entries and exits.
12. New and relocated sewer lines shall be constructed with satisfactory joints, materials and designs which will provide protection and resistance to damage from sulfide gases and other corrosive elements to which they may be exposed.
13. Overhead utility lines should be 20 feet above the operation and maintenance road and/or facilities. Placement of any utility poles shall not interfere with ditch company facilities or operations.

Section B - Safety Fences – (Drawings FDC 002A and FDC 002B)

1. Fences should be installed as specified in Drawings FDC 002A and FDC 002B and as specified below:

Type of Safety Fence	Total Height	Wire Height	Barbed Wire Strands	Posts		Toprail
				Center to Center Spacing	Material	

School	7 ft	6 ft	3	10 ft	Steel	Yes
Urban	6 ft	4 ft	3	10 ft	Steel	Yes
Rural	5 ft	4 ft	2	12 ft	Steel	-----

2. Safety fences should be installed to deter people and animals from entering a canal or ditch.
3. Chain link fences are required in school and urban areas.
4. No-Climb/Horse Wire Low Carbon 12 ½ gauge Class-III Fence is required in rural areas.
5. No. 12 ½ gage galvanized barbed wire with four (4) point barbs, not more than 5 inches apart, is required on top of the fences.
6. A locking device is required on fence gates.
7. Permittee is responsible for the safety fence and shall maintain and repair fences at all times at his/her sole cost and expense and in a condition satisfactory to Florida Ditch Companies. Should the Permittee neglect to promptly make repairs, the Florida Ditch Companies may make repairs or have repairs made and Permittee shall pay all costs and expenses.

Section C – Footbridge Crossings (Drawing FDC 003)

1. Footbridges should be constructed as specified in Drawing FDC 003. Footbridge design drawings must be submitted to the Florida Ditch Companies for review. Cost to review the engineering design will be at the expense of the Permittee.
2. Support beams must be on concrete footing and not in contact with the ground.
3. Decking, support beams, and other bridge features may be made of metal and/or weather protected wood.
4. A minimum of 12 inches must be maintained from the high water mark of the canal and the lowest part of the bridge or any attachments.
5. Handrails are required.

Section D - Culverts (Drawings FDC 004A, 004B, and 004C)

1. Conceptual Drawings FDC 004A, FDC 004B and FDC 004C illustrate general features of a culvert design required by Florida Ditch Companies. Permittee must provide site-specific drawings of existing (if applicable) and proposed plan view (FDC 004A), elevation view (FDC 004B), and ditch profile (FDC 004C) adequate for review by the Florida Ditch Companies. Cost to review the engineering design will be at the expense of the Permittee.

2. Pipe size will be determined based on the canal profile and 125% of maximum flows. Pipe size will be determined by the Florida Ditch Companies' Engineer or applicant's Engineer, at the discretion of the Florida Ditch Companies.
3. Twelve-inch reinforced concrete headwalls are required (See Drawing FDC 004A). A minimum of 24 inches of reinforced concrete is required below the inlet pipe and 16 inches of reinforced concrete above the inlet pipe (See Drawing FDC 004B).
4. Allowable pipe materials include:
 - a. ~~Galvanized corrugated steel (CMP)~~
 - b. ~~Corrugated polyethylene (CPE)~~
 - c. Pre-cast concrete
5. Backfill, as determined by the Florida Ditch Companies, shall be placed around pipe and compacted per specifications.
6. Forty-five degree wingwalls are required at the culvert inlet (See Drawing FDC 004A)
7. No stormwater drainage will be allowed to discharge into the canal, lateral or ditch.
8. Rip-rap is required on the bottom and sides of culvert outlet. The type and amount of rip-rap will be determined by the Florida Ditch Rider.
9. An engineering design and pre-cast concrete culvert with wingwalls boxes may be required for large culverts. This will be determined upon the initial site visit by the Florida Ditch Rider.

NOTES:

1. CROSS THE CANAL OR DITCH UNDER A CULVERT WHENEVER PRACTICAL. CENTER THE CROSSING ON THE CULVERT PIPE.

2. CASING PIPE SHALL BE STEEL PIPE EXCEPT GAS LINES WHICH WILL BE INSTALLED WITHOUT CASINGS. CASINGS SHALL EXTEND FROM RIGHT-OF-WAY LINE TO RIGHT-OF-WAY LINE, UNLESS OTHERWISE APPROVED. REQUIRED CASING DIAMETER AND WIDTH ARE LISTED ON DETAIL A.

3. FOUR SETS OF THREE CREOSOTED WOOD BLOCKS STRAPPED TO CARRIER PIPE PER LENGTH ARE REQUIRED. NEOPRENE OR PVC RUNNERS MAY BE USED AS AN ALTERNATIVE (SEE DETAIL A).

4. CUT-OFF WALLS SHALL BE INSTALLED ON DOWNGRADE END OF ALL UTILITY CROSSINGS AS SHOWN ON DETAIL B.

5. ANNULAR SPACE AT ENDS OF CASING SHALL BE SEALED WITH GROUT OR USE OF WATER TIGHT END SEALS.

6. THE CANAL CROSS-SECTION MUST BE RECONSTRUCTED AFTER THE CROSSING IS INSTALLED TO ITS ORIGINAL SHAPE. BACKFILL MATERIAL MUST BE APPROVED BY THE FLORIDA DITCH COMPANIES AND BE COMPACTED TO A DENSITY EQUIVALENT TO THAT OF THE SURROUNDING INPLACE EARTH MATERIAL OR ADJACENT REQUIRED EARTHFILL (OR 90% OF MAXIMUM DRY DENSITY AS DEFINED BY ASTM D698, STANDARD PROCTOR DENSITY). RECONSTRUCTION IN GUNITED OR FLOWFILL SECTIONS WILL REQUIRE SPECIAL ATTENTION AS DIRECTION BY FLORIDA DITCH COMPANIES.

7. BURIED UTILITIES SHALL HAVE A MAGNETIC WARNING TAPE INSTALLED IN TRENCH FOR DETECTION PURPOSES.

8. PERMITTEE MUST PROVIDE AND INSTALL 5' CARSONITE, OR APPROVED EQUAL, FIBERGLASS SURFACE MARKER WITH LANGUAGE IDENTIFYING UTILITY AT RIGHT OF WAY ENTRIES AND EXITS.

9. 4'-0" MINIMUM UNDER DITCH, CANAL, CULVERT, OR PIPELINE INVERT.

ADAPTED FROM:

NEVADA IRRIGATION DISTRICT AND DENVER WATER DEPARTMENT

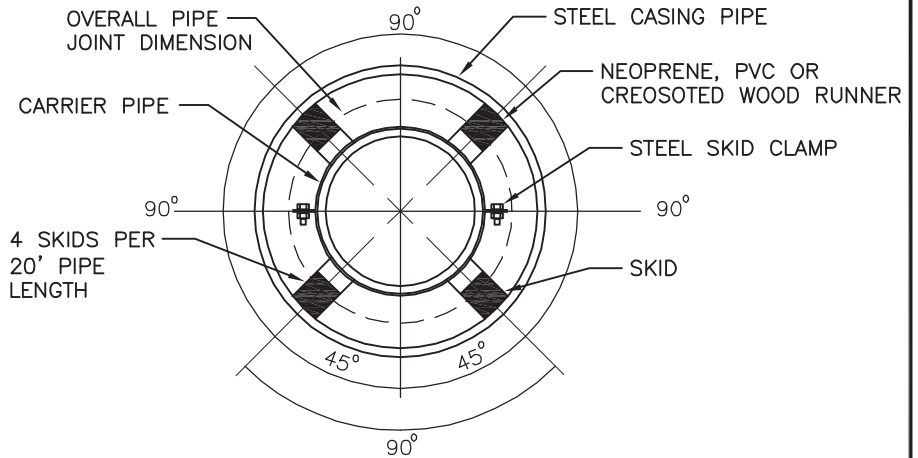

DETAIL "A"
PIPE CASING

N.T.S.

CARRIER PIPE NOMINAL DIA.	CASING PIPE	
	MIN. O.D.	MIN. WALL THICK
4"	12"	0.188"
6"	16"	0.250"
8"	18"	0.282"
12"	22"	0.344"
16"	28"	0.406"
20"	32"	0.469"

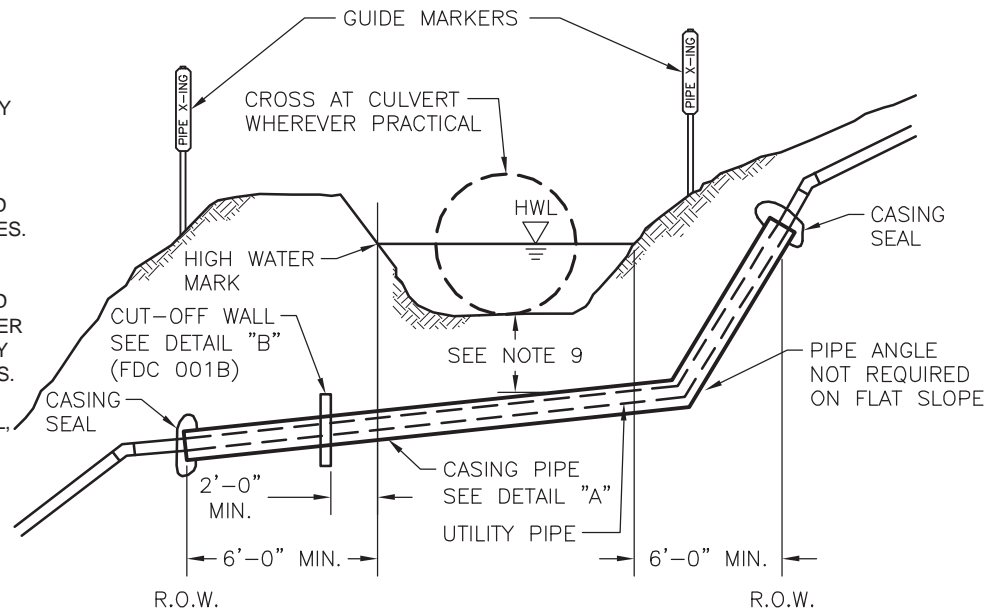

CANAL UTILITY CROSSING (UNDER)

N.T.S.

Plot Date/Time: 09/09/2008, 05:29:17 PM; Z:\PROJECT FILES\06\061-110\010\CAD-GIS\CAD\FDC DETAILS\UTILITY CROSS.DWG-DRAWING 1A

**FLORIDA
DITCH
COMPANIES**

DESIGN BY	-
CHECKED	-
SCALE	NTS
Utility Cross.dwg	

FLORIDA DITCH COMPANIES, LA PLATA COUNTY, COLORADO
**CANAL UTILITY CROSSING (UNDER)
STANDARD DETAIL**

PROJECT NO.	-
DRAWING NO.	FDC 001A

Plot Date/Time: 08/14/2008, 01:35:51 PM; Z:\PROJECT FILES\06\061-110\010\CAD-GIS\CAD\FDC DETAILS\UTILITY CROSS.DWG-DRAWING 1B

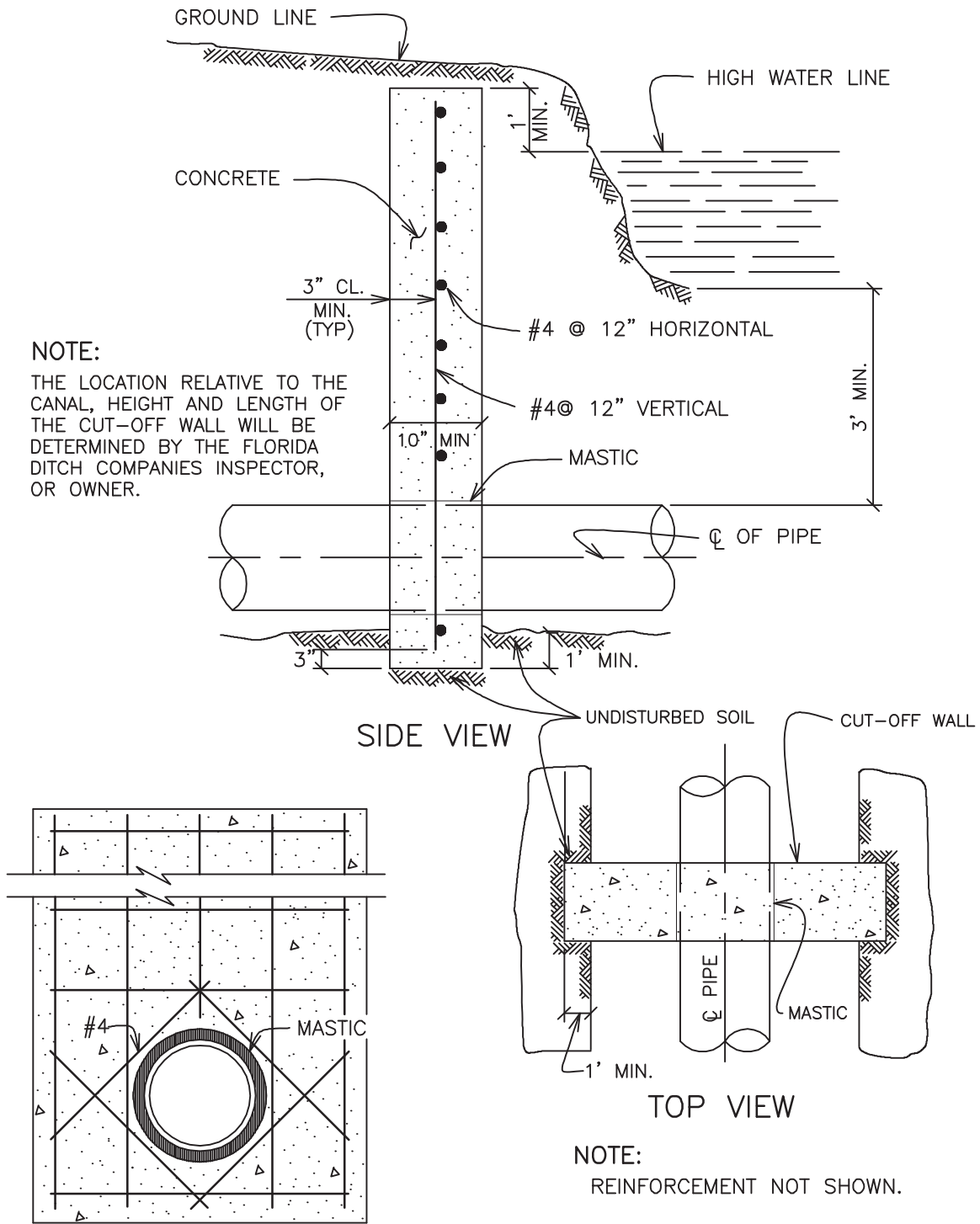

NOTE:
 THE LOCATION RELATIVE TO THE CANAL, HEIGHT AND LENGTH OF THE CUT-OFF WALL WILL BE DETERMINED BY THE FLORIDA DITCH COMPANIES INSPECTOR, OR OWNER.

NOTE:
 REINFORCEMENT NOT SHOWN.

DETAIL "B"
CUT-OFF WALL
 N.T.S.

ADAPTED FROM:
 DENVER WATER DEPARTMENT

**FLORIDA
 DITCH
 COMPANIES**

DESIGN BY	-
CHECKED	-
SCALE	NTS
Utility Cross.dwg	

FLORIDA DITCH COMPANIES, LA PLATA COUNTY, COLORADO
**TYPICAL CUT-OFF WALL
 STANDARD DETAIL**

PROJECT NO.	-
DRAWING NO.	FDC 001B

Plot Date/Time: 08/14/2008, 01:35:37 PM; Z:\PROJECT FILES\06\061-110\010\CAD-GIS\CAD\DETAILS\SAFETY FENCE.DWG-DRAWING 2A

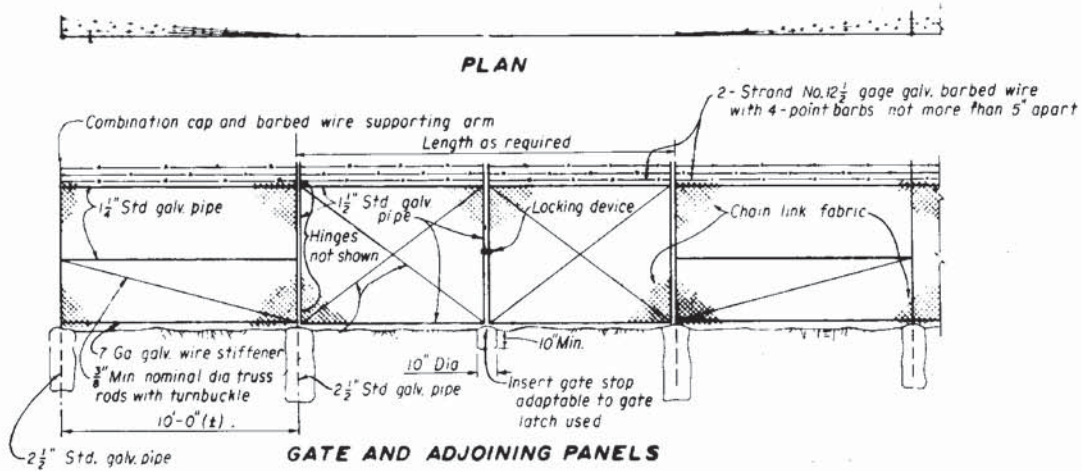

GATE AND ADJOINING PANELS

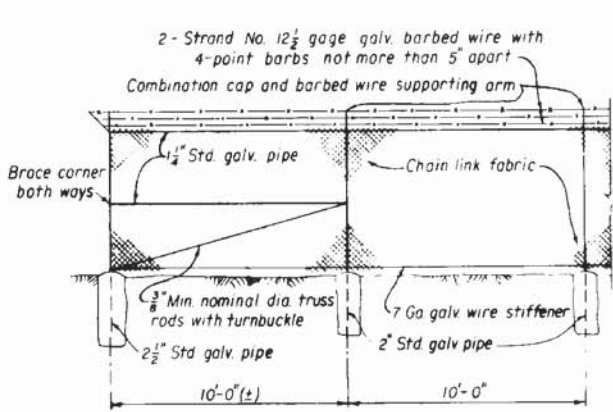

CORNER AND PLAIN PANELS

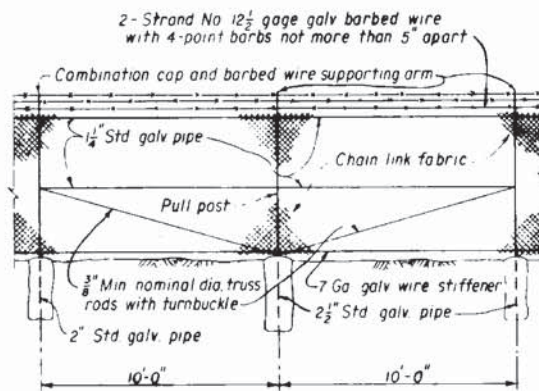

PANELS ADJOINING PULL POST

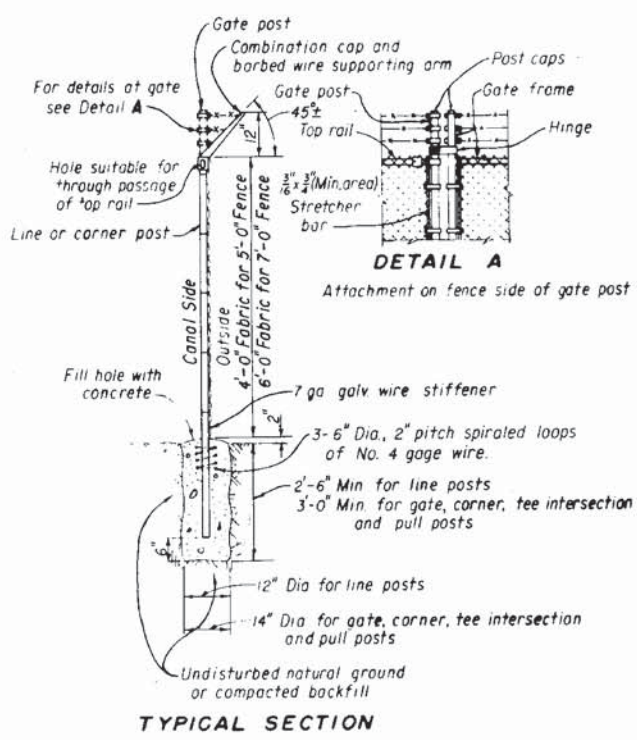

TYPICAL SECTION

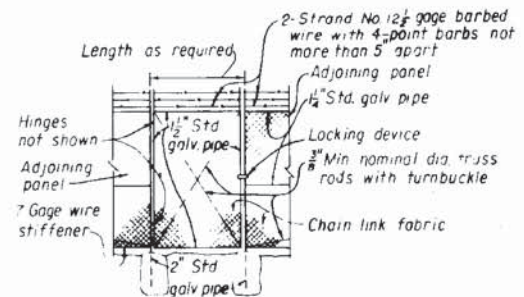

GATE AND ADJOINING PANELS

ADAPTED FROM:
UNITED STATES DEPARTMENT OF THE INTERIOR, BUREAU OF RECLAMATION,
DESIGN OF SMALL CANAL STRUCTURES

- NOTES**
- All pipe diameters shown are iron pipe sizes, standard weight
 - Maximum interval between pull posts 200 feet.
 - Barbed wire guard to be mounted vertically on all gate posts.
 - Chain link fabric shall be attached to fence framework in accordance with the manufacturer's standard instructions
 - Barbed wire supporting arms shall conform with manufacturer's standards or shall be fabricated from 1 1/2 inch pipe. They shall be welded in place or otherwise secured to prevent rotation.
 - School safety fence 7'-0" high.
 - Urban safety fence 5'-0" high.

**FLORIDA
DITCH
COMPANIES**

DESIGN BY	-
CHECKED	-
SCALE	NTS
Safety Fence.dwg	

FLORIDA DITCH COMPANIES, LA PLATA COUNTY, COLORADO
**SCHOOL AND URBAN FENCE
STANDARD DETAIL**

PROJECT NO.	-
DRAWING NO.	FDC 002A

Plot Date/Time: 09/09/2008, 03:18:03 PM; Z:\PROJECT FILES\06\061-110\010\CAD-GIS\CAD-DETAILS\SAFETY FENCE.DWG-DRAWING 2B

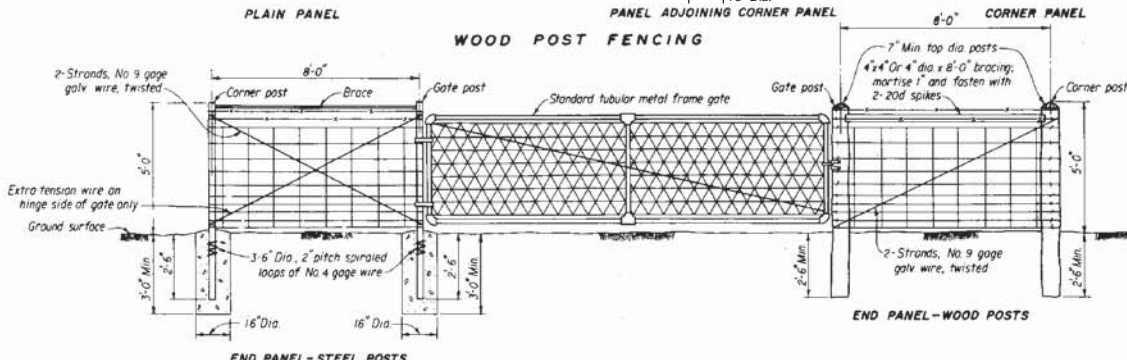
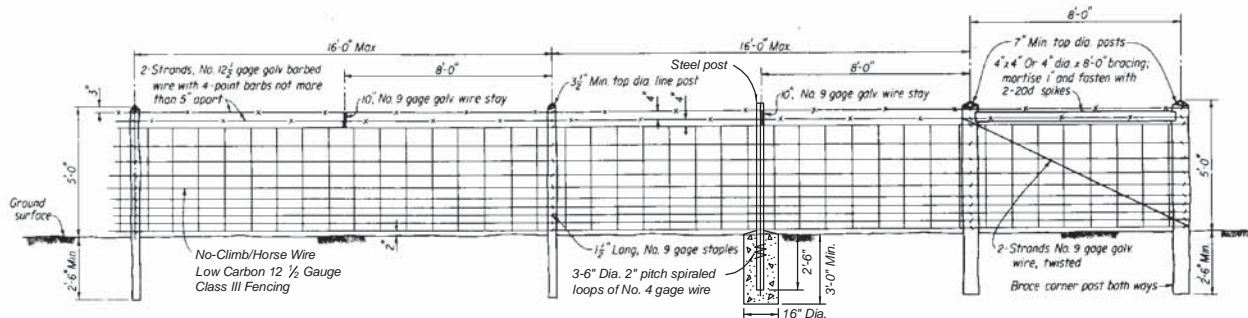

TUBULAR METAL FRAME GATE AND ADJOINING PANELS

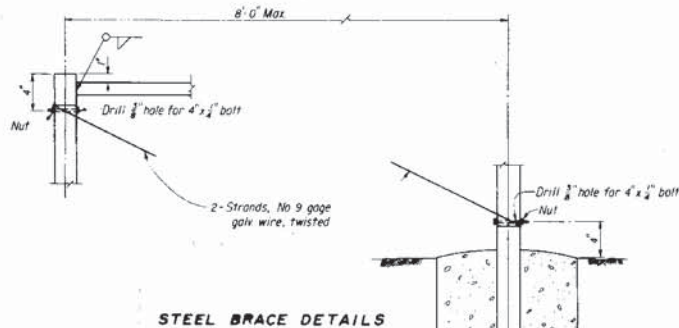
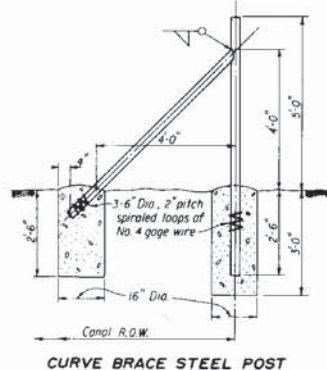
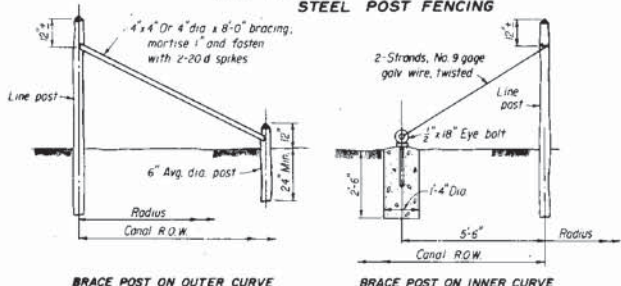
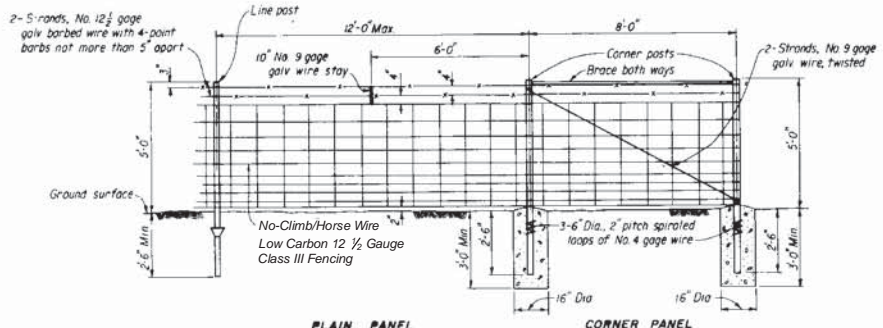

ADAPTED FROM:
UNITED STATES DEPARTMENT OF THE INTERIOR,
BUREAU OF RECLAMATION,
DESIGN OF SMALL CANAL STRUCTURES

NOTES
Maximum length of fence without a corner post, end post, gate post, or brace post shall be 1,000 ft. Additional end panel shall be placed where directed by the contracting officer.
Fence on curve shall have brace posts spaced as follows:
Curve radius less than 500 ft., every 2nd post.
Curve radius 500-1,000 ft., every 5th post.
Curve radius over 1,000 ft., every 7th post.
All steel corner posts and brace posts shall be 2 1/2-inch dia standard weight pipe.
All steel braces shall be 1/2-inch dia standard weight pipe.
For steel gate post size for tubular metal frame gate, see specifications paragraphs.
All wood posts to be placed with butt end down in undisturbed natural ground or compacted fill.
Woven wire fencing shall have No. 10 gage top and bottom wires with No. 12 1/2 gage intermediate and stay wires, spacing of stays to be 12".

**FLORIDA
DITCH
COMPANIES**

DESIGN BY	-
CHECKED	-
SCALE	NTS
Safety Fence.dwg	

FLORIDA DITCH COMPANIES, LA PLATA COUNTY, COLORADO
**RURAL FENCE
STANDARD DETAIL**

PROJECT NO.	-
DRAWING NO.	FDC 002B

NOTES:

1. THIS DRAWING ILLUSTRATES GENERAL FEATURES OF A TYPICAL FOOTBRIDGE. DESIGN DRAWINGS SHOULD BE SUBMITTED TO THE FLORIDA DITCH COMPANIES FOR REVIEW. CONSIDERATION WILL BE GIVEN DURING REVIEW PROCESS AS TO SIZE OF CANAL, ETC., IN DETERMINING ACTUAL REQUIREMENTS.
2. SUPPORT BEAMS MUST BE ON CONCRETE FOOTINGS AND NOT IN CONTACT WITH GROUND. DECKING, SUPPORT BEAMS, AND OTHER BRIDGE FEATURES MAY BE MADE OF METAL AND/OR WEATHER PROTECTED WOOD.
3. A MINIMUM OF 12 INCHES MUST BE MAINTAINED FROM THE HIGH WATER MARK OF THE CANAL AND THE LOWEST PART OF THE BRIDGE OR ANY ATTACHMENTS.
4. THE BERM MUST BE WIDENED IN THE AREA OF THE BRIDGE TO PROVIDE THE SAME UNENCUMBERED WIDTH THAT THE FLORIDA DITCH COMPANIES ENJOYED PRIOR TO BRIDGE INSTALLATION. THIS REQUIREMENT MAY BE WAIVED BY THE FLORIDA DITCH COMPANIES.
5. THE LENGTH OF THE BRIDGE MAY BE REQUIRED TO BE EXTENDED BEYOND THE PRESENT CANAL CROSS SECTION IF AN ENLARGEMENT OF THE CANAL IS ANTICIPATED.

ADAPTED FROM:

NEVADA IRRIGATION DISTRICT

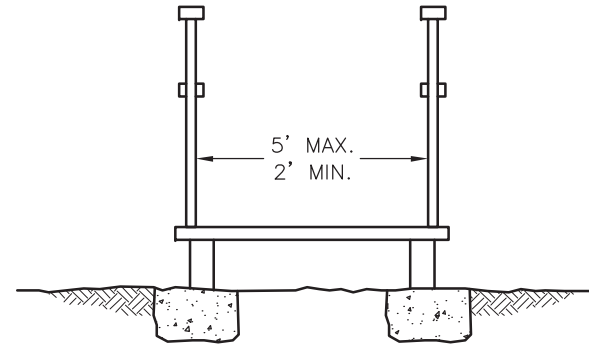

SECTION A-A
N.T.S.

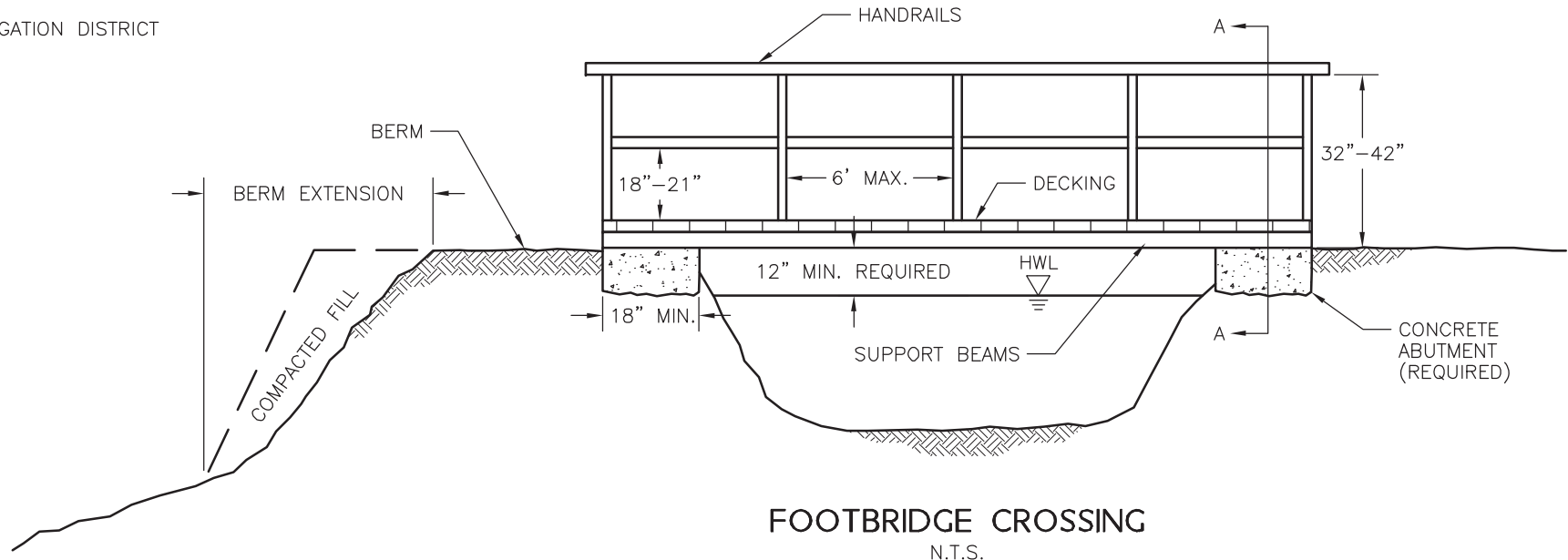

FOOTBRIDGE CROSSING
N.T.S.

**FLORIDA
DITCH
COMPANIES**

DESIGN BY	-
CHECKED	-
SCALE	NTS
Footbridge.dwg	

FLORIDA DITCH COMPANIES, LA PLATA COUNTY, COLORADO
**FOOTBRIDGE CROSSING
CONCEPTUAL DRAWING**

PROJECT NO.	-
DRAWING NO.	FDC 003

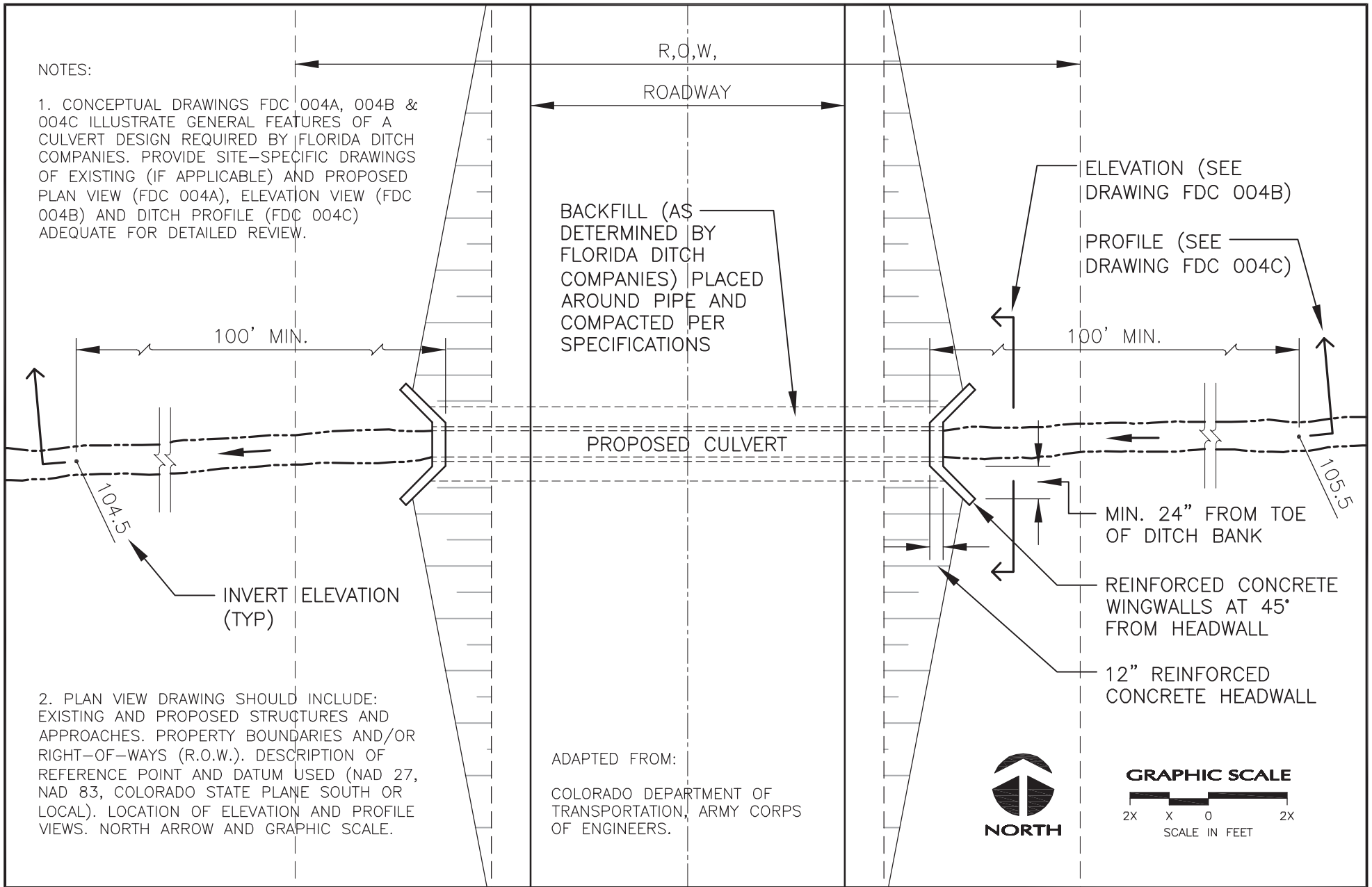

FLORIDA DITCH COMPANIES	DESIGN BY	-	<i>FLORIDA DITCH COMPANIES, LA PLATA COUNTY, COLORADO</i> CULVERT WITH WINGWALLS PLAN CONCEPTUAL DRAWING	PROJECT NO.	-
	CHECKED	-		DRAWING NO.	FDC 004A
	SCALE	NTS			
	Culvert.dwg				

NOTES:

1. CONCEPTUAL DRAWINGS FDC 004A, 004B & 004C ILLUSTRATE GENERAL FEATURES OF A CULVERT DESIGN REQUIRED BY FLORIDA DITCH COMPANIES. PROVIDE SITE-SPECIFIC DRAWINGS OF EXISTING (IF APPLICABLE) AND PROPOSED PLAN VIEW (FDC 004A), ELEVATION VIEW (FDC 004B) AND DITCH PROFILE (FDC 004C) ADEQUATE FOR DETAILED REVIEW.

EXISTING/PROPOSED ROADWAY

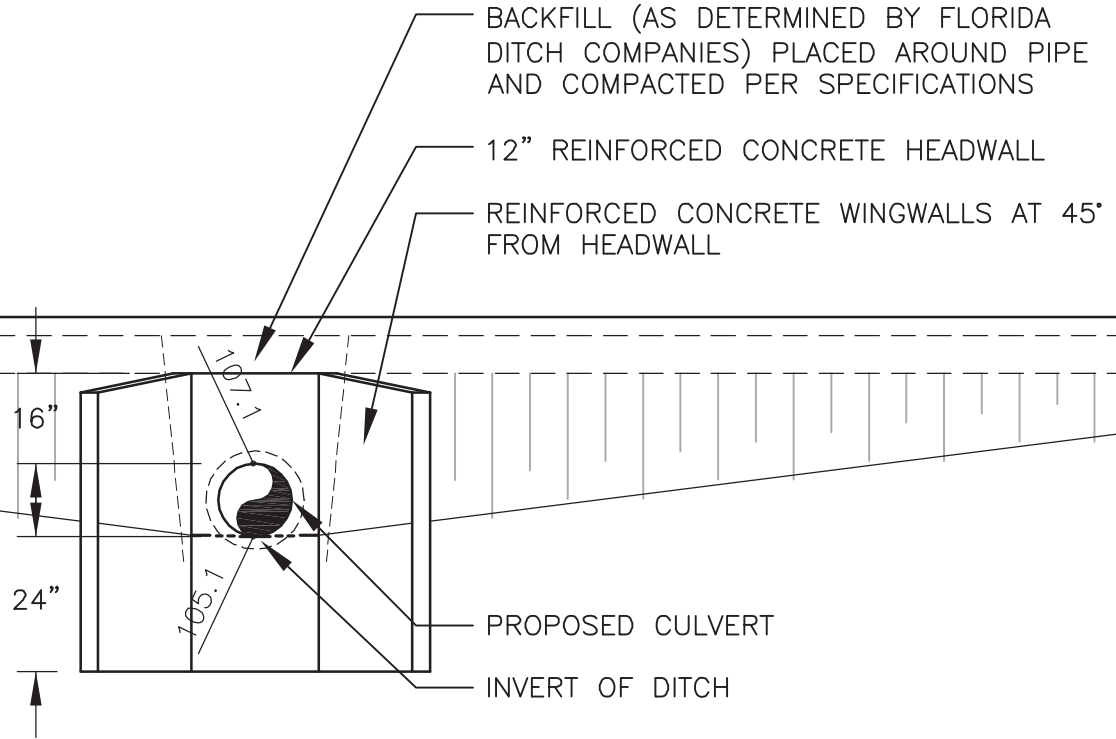

2. ELEVATION VIEW DRAWING SHOULD INCLUDE: EXISTING AND PROPOSED STRUCTURE ELEVATIONS. ROAD GRADE AND ELEVATION OF LOW POINTS IN ROAD. DISTANCE FROM LOW POINT OF ROAD TO MID POINT OF STRUCTURE. UPSTREAM AND DOWNSTREAM ELEVATIONS (FT) OF CULVERT CROWN. HIGHER ELEVATION OF PIPE INVERT OR STREAMBED WITHIN PIPE. OBSERVED AND HIGHEST KNOWN WATER ELEVATIONS (FT) AND DATES OF OBSERVATION (M/D/Y). ELEVATION OF ORDINARY HIGH WATER MARK (OHWM). GRAPHIC SCALE.

ADAPTED FROM:
 COLORADO DEPARTMENT OF
 TRANSPORTATION, ARMY CORPS
 OF ENGINEERS.

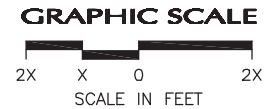

FLORIDA DITCH COMPANIES	DESIGN BY	-	<i>FLORIDA DITCH COMPANIES, LA PLATA COUNTY, COLORADO</i> CULVERT WITH WINGWALLS ELEVATION CONCEPTUAL DRAWING	PROJECT NO.	-
	CHECKED	-		DRAWING NO.	FDC 004B
	SCALE	NTS			
	Culvert.dwg				

NOTES:

1. CONCEPTUAL DRAWINGS FDC 004A, 004B & 004C ILLUSTRATE GENERAL FEATURES OF A CULVERT DESIGN REQUIRED BY FLORIDA DITCH COMPANIES. PROVIDE SITE-SPECIFIC DRAWINGS OF EXISTING (IF APPLICABLE) AND PROPOSED PLAN VIEW (FDC 004A), ELEVATION VIEW (FDC 004B) AND DITCH PROFILE (FDC 004C) ADEQUATE FOR DETAILED REVIEW.

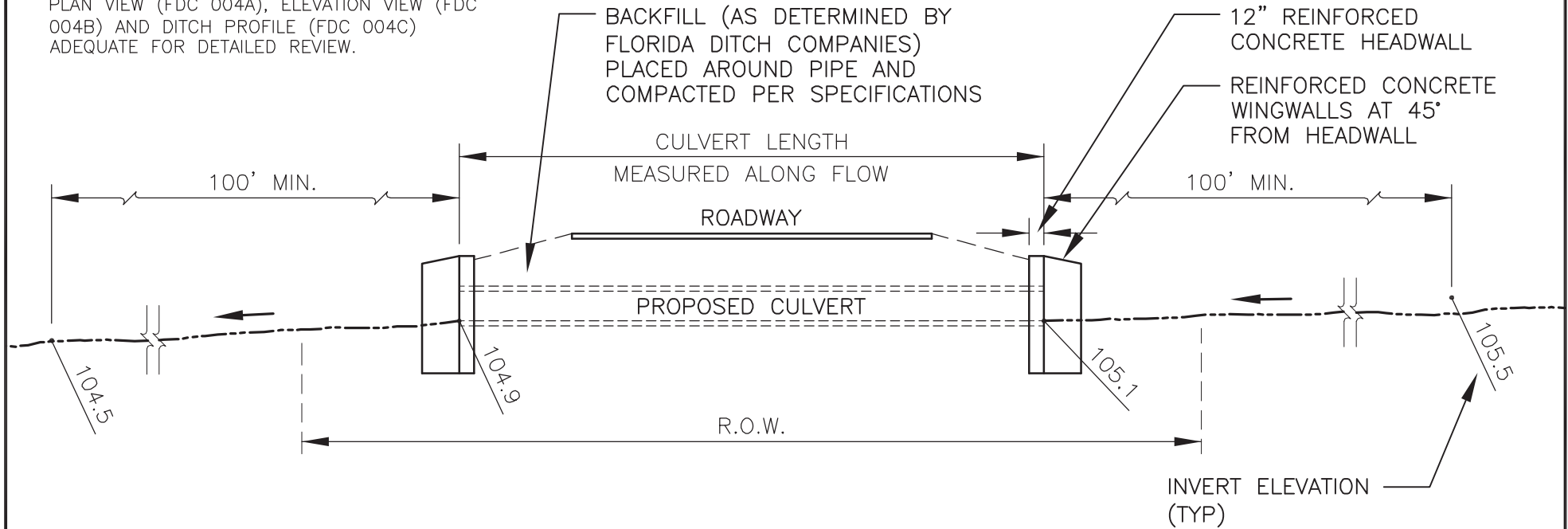

2. PROFILE VIEW DRAWING SHOULD INCLUDE: EXISTING AND PROPOSED ROAD WIDTH AND CULVERT LENGTH. UPSTREAM AND DOWNSTREAM INVERT ELEVATIONS (FT). DATUM USED (NAD 27, NAD 83, COLORADO STATE PLANE SOUTH OR LOCAL). LOCATION OF ELEVATION AND PROFILE VIEWS. GRAPHIC SCALE.

ADAPTED FROM:

COLORADO DEPARTMENT OF TRANSPORTATION, ARMY CORPS OF ENGINEERS.

GRAPHIC SCALE



FLORIDA DITCH COMPANIES	DESIGN BY	-	FLORIDA DITCH COMPANIES, LA PLATA COUNTY, COLORADO CULVERT WITH WINGWALLS PROFILE CONCEPTUAL DRAWING	PROJECT NO.	-
	CHECKED	-		DRAWING NO.	FDC 004C
	SCALE	NTS			
	Culvert.dwg				